

Adobe and Latent Heat: A Critical Connection

John J. Morony
Department of Biology
Southwest Texas Junior College
Del Rio, TX 78840

Mailing Address:
P.O. Box 421627
Del Rio, TX 78842
jmorony@delrio.com

Abstract

A series of ongoing experiments provide evidence supporting the oft-told adage that adobe houses are "warmer in the winter and cooler in the summer" than houses made of other materials. Two modular structures of equal dimension, one of adobe and the other of cinder block, were constructed with 8-inch thick walls, and roofs and floors of identical material. Each structure has an identically constructed and fitted small door for entry of data-gathering instruments. Simple experiments illustrate the thermal properties of adobe (i.e., soil). Adobe still remains soil after its incorporation into a building and thus adobe has the thermal dynamics of soil. Phase change from liquid water to vapor or the reverse will result in a high rate of latent heat to lower or raise the temperature of adobe.

On a dry day, with an out door ambient temperature of 98°F, interior temperatures were 90°F in the adobe structure and 103°F in the cinder block structure. It is proposed that the 13° variation in temperature in the two structures is a direct result of the adobe having lost 8° by way of latent heat of vaporization (in accord with known properties of soil), whereas the cinder block structure *gained* 5° due to simple heat conduction. The reverse occurs when relative humidity is high and temperatures are low. Adobe then takes in moisture from the air, thus releasing latent heat. During cold weather, data loggers for temperature and moisture were placed in each of the modules for ten days. During each diurnal cycle the lowest and highest temperate were restricted to the cinder block.

Clay, the binder in adobe, is hygroscopic and its water content varies with available moisture. Such variation precludes adobe being assigned a specific heat capacity comparable to conventional building material. More importantly, any evaluation of adobe needs to take into consideration dynamic properties of soils (especially the role of latent heat) and not be restricted to the parameters of sensible heat (a static property) by the building industry. Experimental data gathered by the author provides strong evidence that as a construction material adobe blocks keeps a building warmer in the winter and cooler in the summer than cinder block. The explanation for this phenomenon appears to lie in the role of latent heat, not sensible heat -- a critical distinction.

Introduction

Use of cinder blocks for construction of small buildings, especially housing, has almost completely replaced adobe along the Texas-Mexican border. In the Mexican city of Ciudad Acuña, across the river from Del Rio, Texas, perhaps as much as 95% of new home construction, and essentially all government built houses, are of cinder block.

This trend from earthen structure to a cinder block one appears throughout the non-industrial world. Even still, in land where adobe construction had once dominated, the belief of the older populace persists: "Adobe is cooler in the summer and warmer in the winter."

The means for temperature moderation in adobe houses may come from the ease at which moisture enters and leaves permeable and hygroscopic soil in response to changing atmospheric conditions. The movement of moisture in and out of the adobe is more than a simple transfer of water. It is the transfer of latent heat that must take place when there is a phase change in water that raises or lowers the temperature of the building fabric. While adobe and compressed earth blocks have been assigned an R-value of .25/inch, it is the latent heat exchanges that appear to be the dynamic factor to consider most when comparing it to other building materials.

Adobe differs profoundly from all other type building material in that *adobe comes from soil and remains soil after its incorporation into a building*. Latent heat flux is of elementary concern to soil science. Attempts to evaluate adobe exclusively in terms of sensible heat, as with the use of the R-value, or thermal mass, have resulted in confusion in evaluating adobe in terms of thermal properties.

Adobe and its suitability for exceptionally hot climates (as exists along the Texas-Mexico border) are of special interest to this study. Traditional concerns in the United States have been for development of building materials for use in cold climates. Adobe vs. cinder block construction is being studied with a series of simple experiments including the use of two modular structures, one of cinder block and one of adobe. Studies were conducted in Del Rio, Texas in 2003 and early 2004.

Two Modules

Experiment 1: Two modular structures with 8" walls were constructed: one of adobe blocks (8" x 16" x 4") and one of cinder blocks (8" x 16" x 8"). The cinder block was stuccoed with cement and the adobe with lime. Both were left with their natural color. Outside dimensions of both modules are approximately 62" x 48" x 26" with interior volumes about 22 cubic feet each. The roofs and floors of both are constructed of the same material. Both face west and were free of shadows throughout the day (Figure 1). Recording of data was made 27 August 2003 at 4:30 p.m. Modules are located at the *Casa de la Cultura* in Del Rio, Texas.

Figure 1. Experimental modules. Cinder block left and the adobe on the right. With ambient temperature of 98°F, temperatures inside the modules were 103°F in the cinder block and 90°F in the adobe (13° different.) The cinder block was 5° above ambient and the adobe 8° below ambient.

Reference to R-values, or thermal mass, cannot fully explain the 13 degree difference in interior temperature. An 8-inch adobe wall has an R-value of 2 (0.25/inch for adobe) and the cinder block used has an R-value of 1.08. With the lower R-value, the cinder block would be expected to exhibit a higher interior temperature; however the significant difference is that the cinder block was *above* ambient temperature whereas the adobe was *below* ambient. This indicates that there is another important contributing factor beyond the insulating properties of these materials.

Experiment 2: Data loggers were placed in the two previously described modules during acute cold weather from the 25th to the 30th of January, 2004. Data was recorded for temperature, relative humidity and dew point. Only temperature data is illustrated in Figure 2a and 2b.

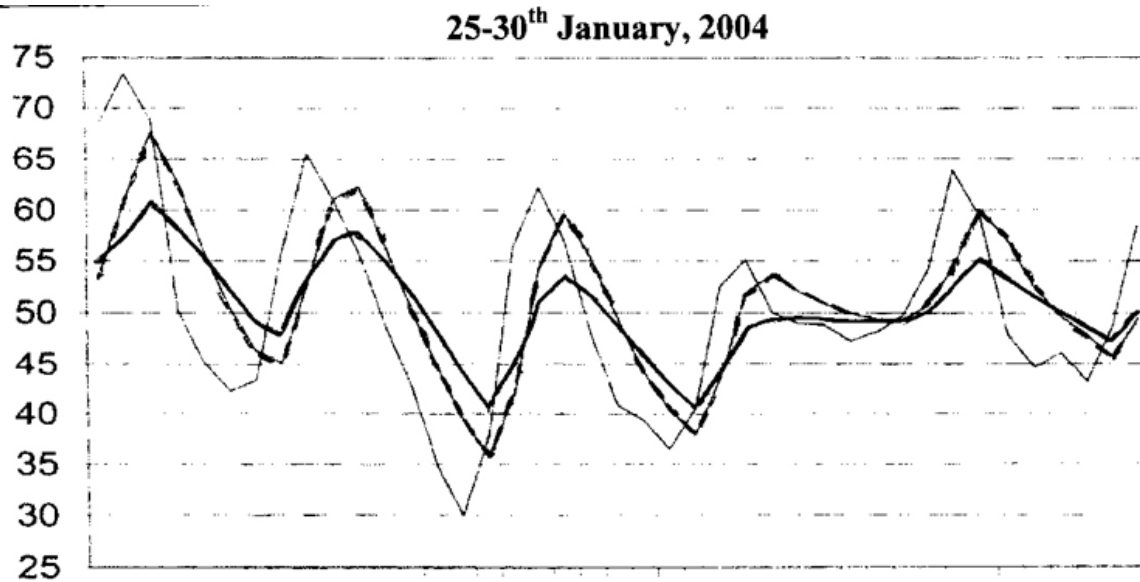

Figure 2a. Temperature data loggings during a cold period (25th to 30th of January 2004). The solid bold line represents adobe; the dashed line represents cinder block and the solid light line represents ambient temperature. Note that for every temperature extremes the cinder block had temperatures higher and lower than the adobe. Also fluctuation of temperature was greater for the cinder block than for the adobe.

Figure 2b. Enlargement of the data on a cold day (January 27, 2004). For that day, the range of temperature was 12°F in the adobe and 24 °F in the cinder block.

Experiments on Latent Heat of Vaporization/Condensation

Effect of latent heat, especially of vaporization, is first demonstrated with simple experiments prior to more discussion. The initial experiment relates the nature of clay and the permeability of clay-rich material to observed results of evaporative cooling or latent heat of vaporization under full sun.

Experiment 3. Four small plastic flower pots are used to demonstrate that heat of vaporization moderates temperature. Three red clay-colored plastic pots and one slightly larger red clay pot were used. One plastic pot was painted black, another painted white and the third was left its original color. The clay pot is left with its natural clay color. The pots had their bottom holes sealed. Each was filled with 500 ml of water and covered with a corresponding colored plastic lid and placed in full sun. Ambient temperature at the time was 94°F in the shade. After being left in full sun for three hours (2:00-5:00 p.m. CST), data were recorded (Figure 3.)

Figure 3. Test flower pots and vaporization of water. Ambient temperature was 94°F.

No.	Pot Color/Type	Temp	Diff	Comments
1	Black	113°F	+19°	No measurable loss of water
2	White	102°F	+8°	No measurable loss of water
3	Natural Clay Color	105°F	+11°	No measurable loss of water
4	Clay Pot	86°F	-8°	56% loss of water

The most dramatic difference is in the temperature of the clay pot; a full 8° below ambient, whereas all the plastic pots were well above ambient. *The clay pot was 19° cooler than the plastic pot of similar color.* Also of note is the large amount of water lost from the clay pot. An explanation is that the clay pot, while being waterproof to liquid water, *it is permeable to*

water vapor that readily diffuses through the sides of the pot. Such movement of water molecules involves a phase change from liquid to water vapor, resulting in the latent heat of vaporization. For each gram of water going from liquid to a vapor state about 580 calories per gram of heat (540 calories per gram for vaporization with the boiling of water) are removed from the clay pot. As the clay pot lost 280 ml of water (one ml of water is equal to one gram) by diffusion there was a total of some 160,000 calories of heat removed from the water! As the heat lost is incorporated into the vaporized water molecules, it is not subject to measurement by a thermometer nor can it be felt -- it is thus 'hidden' heat or latent heat of vaporization as opposed to 'sensible heat' (heat that can be felt and measured).

The plastic pots, being impermeable to water vapor, evaporative cooling was not possible. The difference in temperature of the plastic pots is associated with differing capacity of colors to absorb solar radiation. Black mostly absorbs radiant energy while white mostly reflects it. The rather dark natural clay color is in-between. The contrasting colors of black and white pots translate into difference in temperature in the two pots of 11 degrees.

Experiment 4. The important role of clay and aggregates (sand and silt) in adobe are demonstrated with a simple experiment. Besides serving as the binder in adobe, clay also contributes important thermal dynamics properties. There are two factors to consider in relationship to this: clay particles carry a negative charge and thus water, a polar compound, is readily attracted and attached to clay particles; and simple diffusion of water vapor from high to low concentration varies throughout the day in response to changes in atmosphere moisture. The presence of aggregates in the adobe provides pathways for capillary action, allowing water molecules to move in and out.

Figure 4. Moisture absorbed by clay in response to changes in relative humidity. The result in exposing a cube of a compressed earth block to conditions of a hot dry climate (Del Rio, Texas from August to 20 to 24, 2003.) Weights were recorded in early morning and late afternoon.

Weight	Totals	Weight	Total
High RH, a.m.	Low RH, p.m.	loss of moisture	loss of heat
261.0 g	257.9 g	3.1 g	1,674 cal
261.0 g	257.4 g	3.6 g	1,944 cal
260.2 g	258.4 g	1.8 g	972 cal
261.2 g	258.7 g	2.5 g	1,350 cal

Percent of weigh gain may be small, but the latent heat of vaporization that it represents is extremely great. The specific heat of water is much higher than any conventional building material.

Experiment 5. Three clay pots were used to determine the effects of color on evaporative cooling. One pot was painted with white enamel, one with white lime wash and the third was left its natural clay color. The bottoms of the pots were sealed, the pots filled with water, covered with a cap of similar color and placed in full sun. Any differences in evaporation between the while colored posts, related to the nature of the coating material, will be revealed.

Figure 5. Small clay flower pots filled with water: #1 lime wash; #2 enamel paint; #3 unpainted clay color. Pots exposed to full sun with for three hours in late afternoon. Ambient temperature of 94°F.

Limewash	Enamel Paint	Unpainted
78°F	94°F	88°F
16° below ambient	no change	6° below ambient

The limewashed clay pot is now *16° degrees below ambient temperature!* The high reflectance of the white limewash significantly limits the amount of radiant energy absorbed to convert into thermal energy as sensible heat. At the same time, lime remains vapor permeable *and thus permits evaporative cooling.*

The white enamel on the pot succeeds in greatly reducing the conversion of radiant to thermal energy, but because it is impermeable to water vapor it *prevents* evaporative cooling.

Experiment 6. Three clay flower pots were used to determine the effects of color on temperature when no evaporative cooling was allowed to occur (Figure 6.) One pot was painted with white enamel, one with white limewash and the third was left its natural red clay color. The pots were placed upside down in full sun. Inside temperature was measured with a thermometer inserted in the hole in the bottom of the pot.



Figure 6. Large clay pots turned upside down exposed to ambient condition in full sun; #1 enamel white; #2 white limewash; #3, natural clay color. Inside temperatures recorded after three hours exposure and subsequent gain in temperature is recorded. Ambient temperature of 94°F.

1	2	3
104°F	98°F	104°F
+10°	+4°	+10°

Note that the limewash is highly effective in reflecting solar radiation. Limewash is a mixture of slaked lime (calcium hydroxide) and water. When applied as a near water-thin paint it sets slowly by absorbing CO₂ from the air, producing crystals of calcite (CaCO₃, calcium carbonate). Unlike paints that are organic polymers, limewash is a mineral of *dual reflective index* and thus more effective in reflecting solar radiation. The limewash is 6° lower than the enamel.

Latent Heat and Building Materials

Phase change material (PCM) is any substance capable of latent heat flux and it has been of interest to the building industry since at least the 1940s. Stored energy in latent form within a building fabric would lead to greater heat storage capacity per unit volume than would be otherwise possible with conventional building materials. The concern has focused almost entirely on providing warmer indoor temperature in the winter. Interest in the matter appears

to have been restricted to heat of fusion and an inventory of PCM did not include soil. It was initially restricted to a list of inorganic chemicals (largely hydrated salts) that would have to be incorporated *into* a building fabric and none constituting the building fabric itself. Nothing really workable emerged from these efforts. Interest then turned to organic PCM but with like consequences.

Soil, suitable for earthen block making, is inherently phase change material *par excellence*. Most significantly, it constitutes not only the entire building fabric as to heat of fusion but to vaporization and condensation as well -- and it does so to a degree far in excess of almost all other materials man-made or otherwise.

The Nature of Adobe vs. Cinder Block

Clay is the binding material of adobe with silt and sand serving as the aggregate, often with the addition of fibrous organic matter by way of straw or horse manure. In construction of an adobe block, *clay remains chemically unaltered*. Adding water serves to facilitate rearrangements and compaction of the particles in making adobe blocks. The clay in the adobe block retains its capacity to attract water after the block is made. This water can move in and out via capillary action in response to available moisture along the pathways created by the contained aggregate.

In contrast, Portland cement (a highly complex and altered very fine powder predominantly limestone) undergoes a chemical transformation into concrete when mixed with water and an aggregate. While some capacity for capillary action may remain, it is much reduced compared with adobe or other earthen building materials. Importantly, the clay content of Portland cement has been chemically altered and is no longer hygroscopic. This distinction between earthen material and products incorporating Portland cement (or stone and brick for that matter) as building material is critical to appreciating their thermal character.

A Scaled-up Model to Consider

To scale up from the small modules, previously discussed, an appreciation of the thermal properties of an existing adobe dwelling is provided by a study published in *Earthbuilder* (10th Anniversary Issue 42, 1984, p. 56, Adobe News, Inc.) The house, described as an "old style adobe", was located in Los Lunas, Rio Grande Valley, New Mexico at an elevation of 4,750 feet. The building had 17-inch thick walls and an 8- to 12-inch thick earthen roof. Temperature was recorded in two intervals: before and after expansion to the house. The initial floor plan, of less than 1,000 square feet is illustrated below (Figure 7).

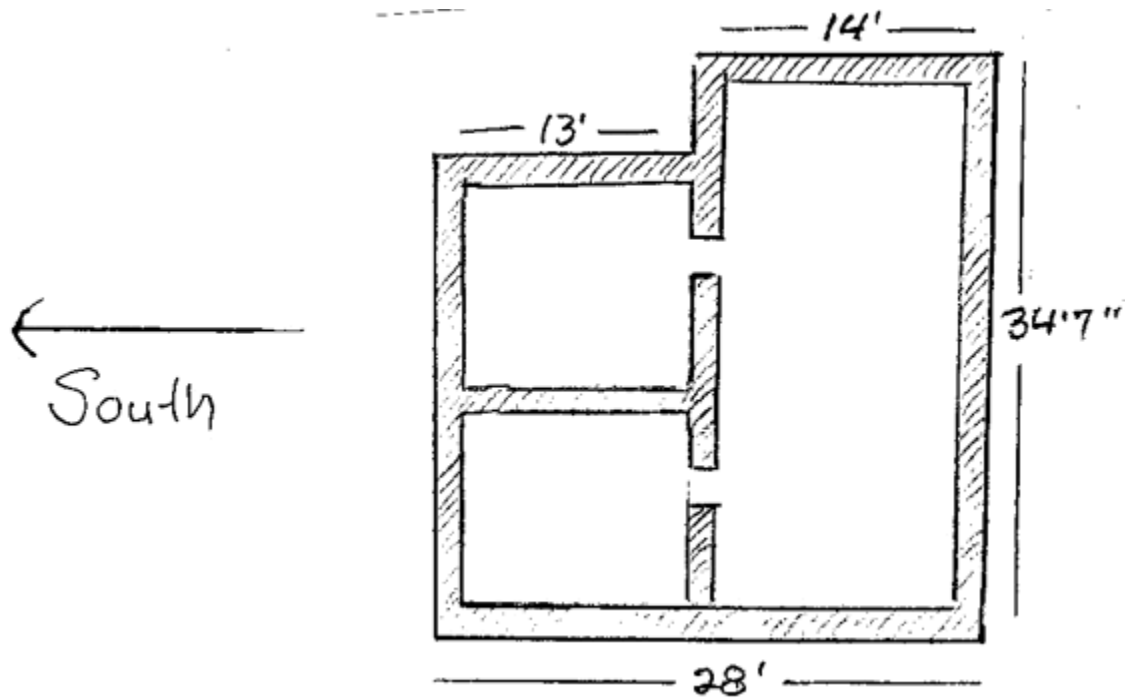

Figure 7. Original floor plan as of June 14, 1976. No insulation was used and no cooling mechanisms or overhangs existed. There was one window on the north side. Late in the day a large tree partially shaded the northwest corner of the house. The building was kept closed during the period the data was gathered.

Temperature data for the adobe house on June 14, 1976:

Time	Inside Temp.	Outside Temp.
12:30 pm	79.0	99.0
1:30 pm	79.5	101.5
2:30 pm	80.0	102.0
3:30 pm	80.0	99.5
4:30 pm	79.0	88.0
6:30 pm	79.5	89.0

Inside temperature of the adobe did not exceeded 80° F when outside temperatures average in the mid- to upper 90s. Note that when outside temperature was 102°F, inside temperature was 80°F (a 22° difference!) The authors state that there was an inside temperature variation of only 5° in the house from May 27 to July 11 of that year, and further note that this was with no roof insulation or cooling unit of any kind. Significantly, the authors comment that it was noted that the inside *high temperature* occurred during the *morning hours*, at roughly 12 hours after the outside high of the preceding day. Likewise, the *inside low* temperature appeared in *mid-to late afternoon*, roughly 12 hour after the morning outside low temperature. That inside temperatures of an adobe house would be cooler when outdoor ambient temperature is highest and warmer inside when outdoor temperatures are coolest is clearly counter-intuitive! However, the adobe is responding not to sensible heat of the environment, but rather to a differential of moisture content on either side of an adobe enclosure.

Latent heat of condensation would be expected to occur in the morning hours when relative humidity is highest and outside temperature is coolest. The absorption of moisture by the clay in the adobe would result in *raising the temperature of the adobe*. In the late afternoon, when relative humidity is the lowest, latent heat of vaporization (evaporative cooling) would exhibit

a reverse effect, i.e., *adobe would actually cool*. However, the explanation provided by the author centered on what is said to be the 'flywheel effect'. This is an untested assumption that a delay in the conduction of heat in and out of the adobe house would be due to sheer mass of the wall. A question arises: what is the annual energy cost required to maintain a comparable inside temperatures of a building not susceptible to latent heat flux?

Summary

The preliminary results of a series of ongoing experiments may be summarized as follows:

1. Adobe is indeed cooler in the summer and warmer in the winter, and significantly so, in comparison to cinder block and other non-earthen building materials. The reason for this is not directly related to sensible heat of conduction, but rather to latent heat and especially latent heat of vaporization and condensation. Latent heat flux appears to stabilize internal temperatures within an adobe enclosure.
2. Thermal qualities of adobe and other earthen materials cannot be accurately expressed or understood using only the R-values of conventional building material. The "guarded hot box", used to determine the R-values, measures steady-state heat flow of differential heat on either side of the material being tested. For adobe, it is the latent heat flux promoted by a moisture differential on either side of a wall of an enclosed adobe building that lowers and raises the temperature of the adobe. The concept of insulation, as it is applied to conventional building materials, is of doubtful use or significance.
3. Caution is suggested in the use of any material, modifications or structural design that might impede the thermal dynamics of latent heat flux of earthen structures.
4. Latent heat phenomena would appear to strongly favor what has come to be known as a "green roof" for adobe structures.
5. Adobe and similar materials must be recognized for what they are -- a very superior building material both from the standpoint of their functional value and cost. Economically, the price of soil is not tied to the price of oil, and the costs for heating or cooling would be significantly reduced in a rightly constructed earthen structure.